

ASCENDO

SYSTEM M-S

USER'S MANUAL

Contents

1	OVERVIEW	3
1.1	Overall Picture	3
1.2	Application	4
1.3	Safety Warning	4
1.4	Operating modes	4
1.5	Technical Data	5
2	INSTALLATION	6
2.1	Demands of speaker location	6
2.2	Mounting	6
3	TRANSPORT	8
4	CONNECTION	9
5	TIME ALIGNMENT FOR THE LISTENER'S POSITION	12
5.1	Adjustment of the Time alignment	13
6	CLEANING	14

ASCENDO GMBH
HÖLDERLINWEG 6
73257 KÖNGEN
GERMANY

Phone: 0049 (0) 7024 9288 84

Fax: 0049 (0) 7024 9288 64

MAIL: MAIL@ASCENDO.DE

www.ascendo.de

1. Overview

The ASCENDO System M-S is a three-way Loudspeaker constructed with ASCENDO's SASB-Technology.

The strictly modular design leads to several advantages.

- perfect phase reconstruction at the actual position of the listener by time alignment.
- consequently mechanical and electrical decoupled: more details and transparency.
- very low resonance between loudspeaker and floor.

The crossover, low-frequency-unit and high-frequency-unit can be adjusted for different amplifiers and cables.

1.1 Overall Picture

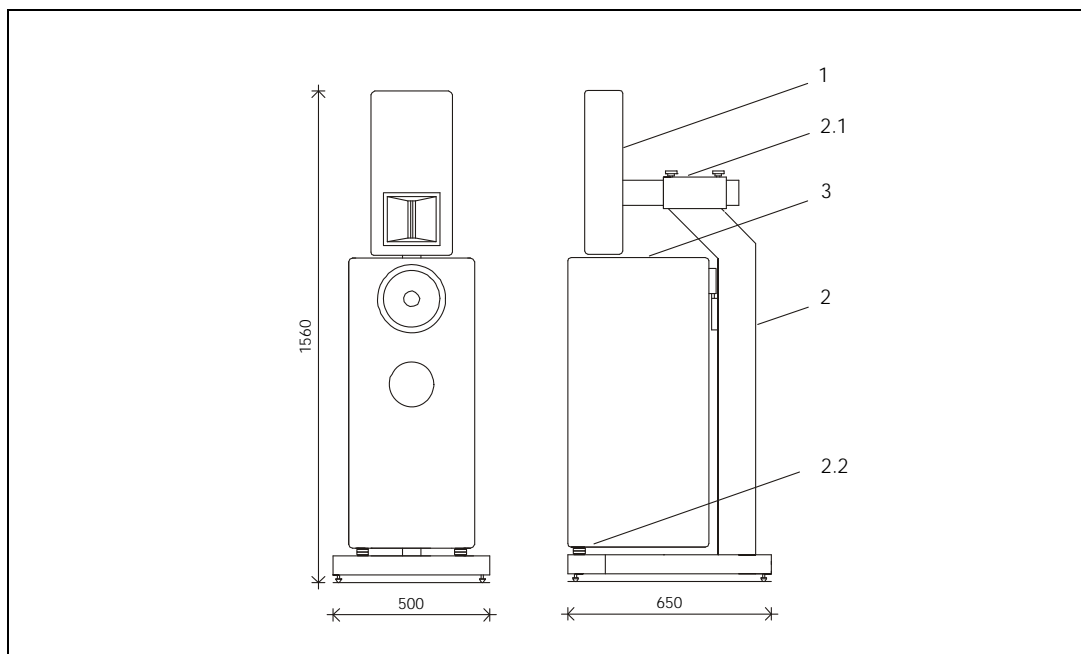

- | | |
|-----|------------------------------|
| 1 | High-Frequency-Unit |
| 2 | Stand |
| 2.1 | Drive of High-Frequency-Unit |
| 2.2 | Damper |
| 3 | Low-Frequency-Unit |

1.2 Application

The ASCENDO Loudspeaker System M-S is intended for use in small to mid-size rooms (< 150 m³, see section 2.1).

You can use the System M-S with amplifier in the power range of 10 W to 500 W.

1.3 Safety Warning



Warning

This Loudspeaker can produce big sound-levels. This may damage your ears permanently!

1.4 Operating modes

You can use the System M-S in a single-amp setup (one power amplifier for high- and low-frequency unit) or in a bi-amp setup (one power amplifier for the low-frequency-unit, one for the high-frequency unit) or in a tri-amp setup (one power amplifier for the low-frequency-chassis, one for the middle-frequency chassis, one for the high-frequency unit).

If your setup is single-amping you must bridge the high- and low-frequency unit with a high quality speaker cable.

1.5 Technical Data

Principle	Three-way SASB- technology
Construction	modular, low-resonance mounting of units variable time-alignment for listener's position between 50 cm and 190 cm over floor.
Material	Steel Low-Magnetic Stainless-Steel sandwich construction of Bitumen and MDF
Dimensions	50 / 156 / 65 cm
Weight	100 -120 kg (without/with sand in the stand)
Power	600 W RMS (min.)
Impedance	8 Ohm
Sensitivity	91 dB/1W/m
High-Frequency Unit	Driver: Ribbon Tweeter Switch for high and low damping-factor of amp
Low-Frequency Unit	Outer Chassis: 21cm, HPS diaphragm, phase plug Inner Chassis: 28 cm, Hexacone diaphragm Switch for high and low damping-factor of amp
Connector	Si / Bi / Tri-Wiring
Finish	Piano lacquer: black / white

2. Installation

2.1 Demands of speaker location

- Use the System M-S in closed rooms only. Do not expose the speaker to high humidity, direct water and direct sunbeam.
- Take care of a minimum distance of 2 m of the speaker to monitors (TV, computer) and magnetic devices (audio/video-cassettes, floppy-disks, etc.).

WARNING

There may be a slight permanent imprint in soft floor-material!

2.2 Mounting

WARNING

Don't try to mount the System M alone. The weight of the high- and low-frequency unit is too much for a single person. You need at least two persons to build up the system.

1. Place the stand (2) carefully at the desired place.
2. Adjust the stand (2) for your specific hearing position.

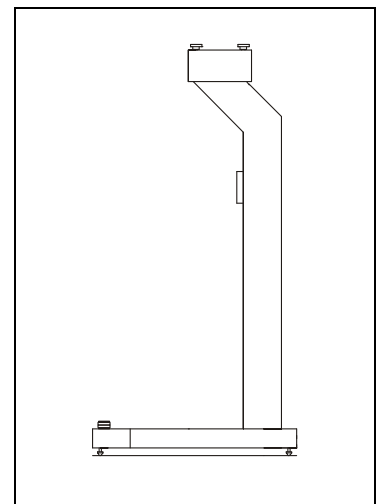

3. Place the damper (2.2) on the stand.

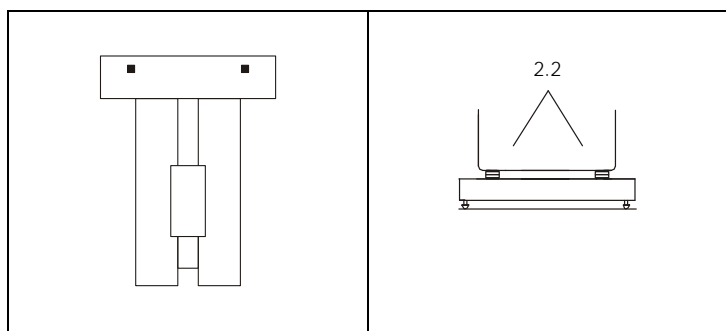

3. Place the low-frequency unit (3) in the stand (2). Be careful of the right placement of the upper back-spike.

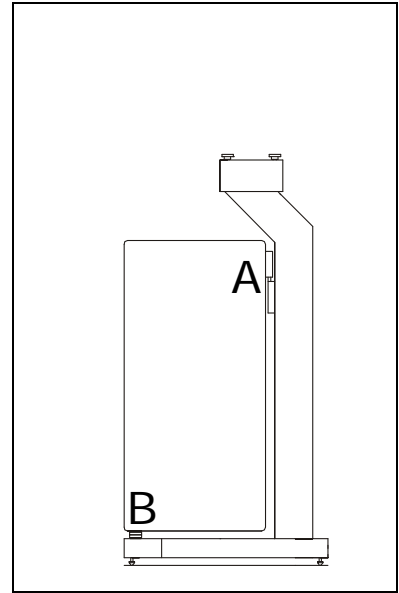
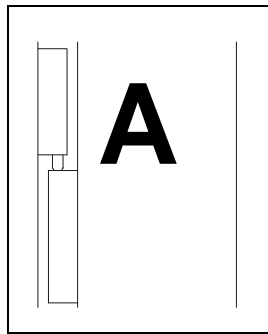
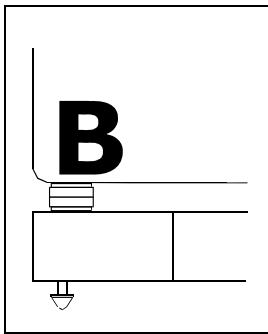

4. Place the high-frequency unit (1) in the stand (2.1). Adjust the unit as described in section 5.
5. Connect the units with your power amplifier(s). See section 4.

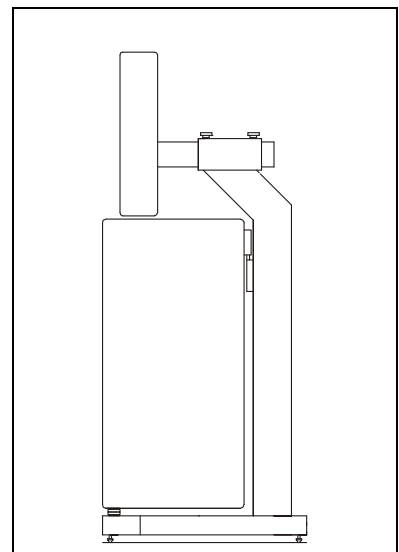

3. Transport

Warning

Don't try to move or transport the System M-S alone! The weight affords at least two persons.

1. Switch off the power amplifiers and disconnect all cables of the System M-S.
2. Untie the screws (8).

**Warning**

The high-frequency unit has an excentric center of mass and is very heavy. It can cause serious damages. Don't try to pull it off the stand alone!

3. Pull off the high-frequency unit from the stand (2). Lay it on a soft dry cloth. Take care not to touch the diaphragm of the tweeter.
4. Lift the low-frequency unit from the stand and the upper back-spike. Take care not to touch the diaphragm of the woofer.
5. Place the stand (2) at its new position.

4 Connection

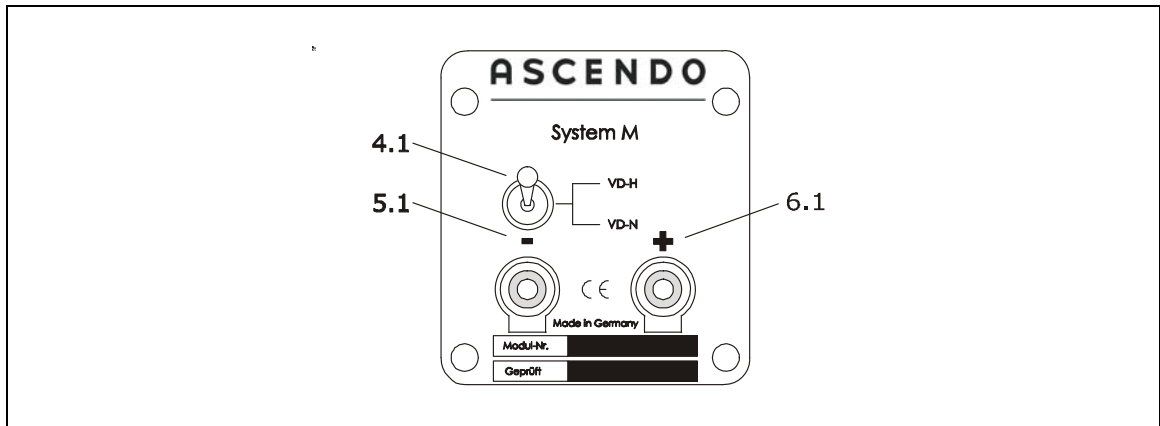

- 4.1 Switch / High-frequency-unit
- 5.1 Minus / High-frequency-unit
- 6.1 Plus / High-frequency-unit

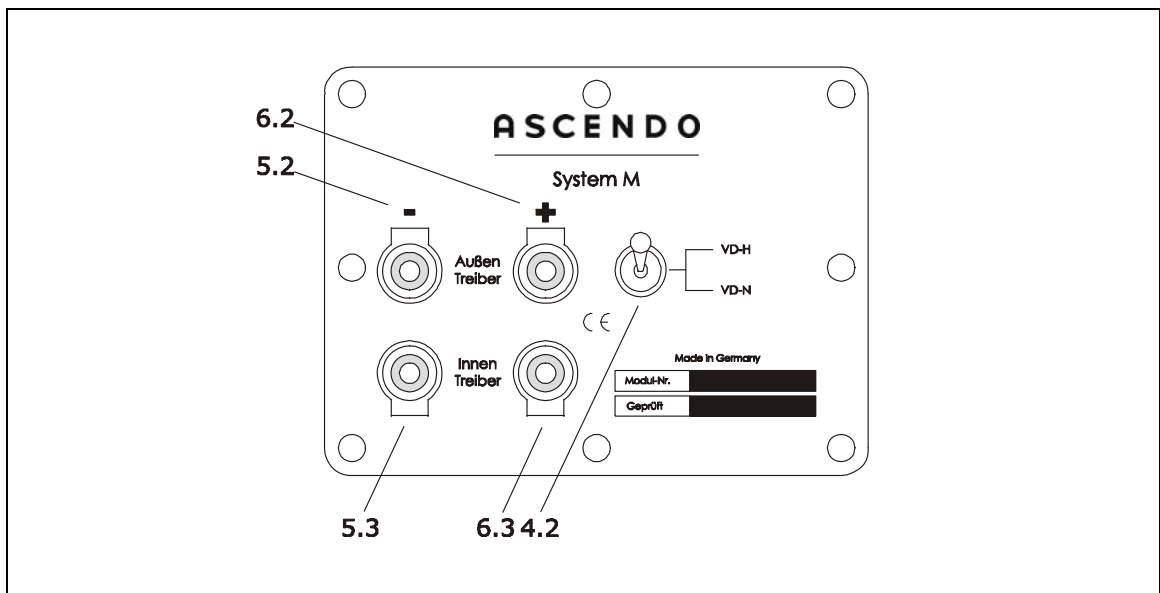

- 4.2 Switch Low-frequency-unit
- 5.2 Minus / Low-frequency-unit / outer chassis
- 6.2 Plus / Low-frequency-unit / outer chassis
- 5.3 Minus / Low-frequency-unit / inner chassis
- 6.3 Plus / Low-frequency-unit / inner chassis

The high- and low-frequency unit can be connected as follows:

- **single-wired:**

- one cable-pair from power-amp to high-frequency unit
- one cable-pair from low-frequency unit to high-frequency unit
- one cable-pair from inner chassis to outer chassis

- **bi-wired:**

Version1:

- one cable pair from power amp to low-frequency unit
- one cable pair from the power amp to high-frequency unit
- one cable pair from inner chassis to outer chassis

Version2:

- one cable pair from power amp to inner chassis
- one cable pair from the power amp to high-frequency unit
- one cable pair from high-frequency-unit to outer chassis

- **tri-wired:**

- one cable pair from power amp to outer chassis
- one cable pair from the power amp to inner chassis
- one cable pair from the power amp to high-frequency unit.

- **bi-amped:**

Version1:

- one cable-pair from separate amps for low- and high-frequency unit
- one cable-pair from inner chassis to outer chassis

Version2:

- one cable-pair from two separate amps for inner chassis and high-frequency unit
- one cable-pair from high-frequency unit to outer chassis

- **tri-amped:**

- one cable-pair from three separate amps to inner chassis, outer chassis and high-frequency unit.

Take care of connecting always the plus (red) terminal of your power amp with the plus (+ / red) terminal of the speaker!

Take care not to connect a plus with a minus pin of your cable!

The speaker-units are adjustable to the characteristics of your power-amplifier. Since these differ strongly you have to check the best switch position for your specific setup. These are the key-rules for the adjustment:

High-frequency unit

Switch (4) in position VD-N

- This is recommended for transistor power amps with damping-factor falling with frequency

Switch (4) in position VD-H (Standard)

- Recommended for transistor power amps with constant damping factor

Low-frequency unit

Switch (4) in position VD-N

- This is recommended for fast transistor power amps.

Switch (4) in position VD-H (Standard)

- Recommended for transistor amps with strongly load- dependent output-power

5. Time alignment for the listener's position

To achieve a perfect phase reconstruction, at the actual position of the listener, the delays of the transducers must be adjusted carefully. The position of the tweeter has to be mechanically adjusted, so that a plane wave will leave the speaker system exactly in the direction to the listener's ear. This is possible owing to the specific design of the ASCENDO Systems. The displacement of the cylindrical tweeter mounting ensures the correct phase in over-floor positions between 50 cm and 190 cm. A scale in the stainless steel cylinder allows a reproduce able adjustment.

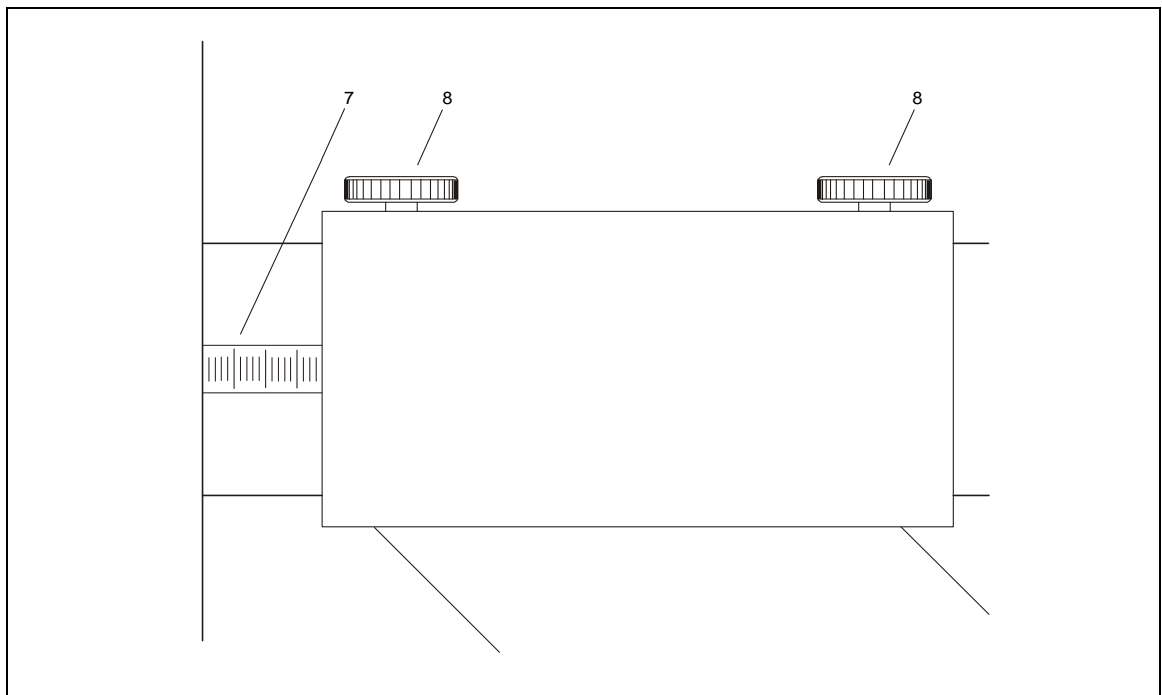

- 7 Scale
- 8 High-frequency unit screws

1. Switch off the power amps.
2. Untie the screws (8).



Warning

The high-frequency unit has an excentric center of mass and is very heavy. It can cause serious damages. Don't try to pull it off the stand alone!

4. Adjust the high-frequency unit to the desired position.
5. Fasten the screws (8).

5.1 Adjustment of the time alignment

Conditions:

1. Coplanar setup (left and right speaker)
2. Adjustment to hearing position
3. High-frequency unit switch in position "VD-H"
4. Low-frequency unit switch in position "VD-H"
5. 0-phasis of amplifier

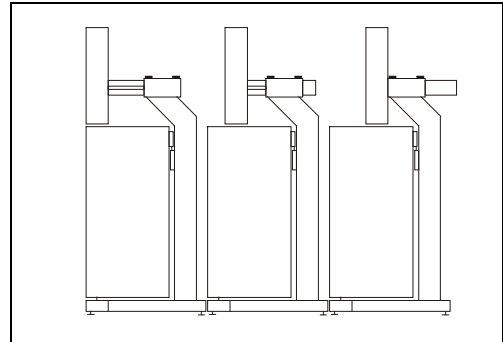

		Distance (Ear) in cm																				
		150	160	170	180	190	200	210	220	230	240	250	275	300	325	350	375	400	425	450	475	500
80,0	Scale	16,5	16,7	16,9	17,0	17,2	17,3	17,4	17,5	17,5	17,6	17,6	17,8	17,9	18,0	18,0	18,1	18,1	18,2	18,2	18,2	18,3
	80,0	16,5	16,7	16,9	17,0	17,2	17,3	17,4	17,5	17,5	17,6	17,6	17,8	17,9	18,0	18,0	18,1	18,1	18,2	18,2	18,2	18,3
	82,5	16,3	16,5	16,6	16,8	16,9	17,0	17,1	17,2	17,3	17,4	17,4	17,5	17,6	17,7	17,8	17,9	17,9	18,0	18,0	18,0	18,1
	85,0	16,0	16,2	16,4	16,5	16,7	16,8	16,9	17,0	17,0	17,1	17,2	17,3	17,4	17,5	17,6	17,6	17,7	17,7	17,8	17,8	17,8
	87,5	15,7	15,9	16,1	16,3	16,4	16,5	16,6	16,7	16,8	16,9	16,9	17,1	17,2	17,3	17,4	17,4	17,5	17,5	17,6	17,6	17,6
	90,0	15,4	15,7	15,9	16,0	16,2	16,3	16,4	16,5	16,6	16,6	16,7	16,9	17,0	17,1	17,1	17,2	17,3	17,3	17,3	17,4	17,4
	92,5	15,2	15,4	15,6	15,8	15,9	16,0	16,1	16,2	16,3	16,4	16,5	16,6	16,7	16,8	16,9	17,0	17,0	17,1	17,1	17,2	17,2
	95,0	14,9	15,1	15,3	15,5	15,7	15,8	15,9	16,0	16,1	16,2	16,2	16,4	16,5	16,6	16,7	16,8	16,8	16,9	16,9	17,0	17,0
	97,5	14,6	14,9	15,1	15,3	15,4	15,5	15,7	15,8	15,8	15,9	16,0	16,2	16,3	16,4	16,5	16,5	16,6	16,7	16,7	16,7	16,8
	100,0	14,3	14,6	14,8	15,0	15,2	15,3	15,4	15,5	15,6	15,7	15,8	15,9	16,1	16,2	16,2	16,3	16,4	16,4	16,5	16,5	16,6
	102,5	14,1	14,3	14,6	14,7	14,9	15,0	15,2	15,3	15,4	15,5	15,5	15,7	15,8	15,9	16,0	16,1	16,2	16,2	16,3	16,3	16,3
	105,0	13,8	14,1	14,3	14,5	14,7	14,8	14,9	15,0	15,1	15,2	15,3	15,5	15,6	15,7	15,8	15,9	15,9	16,0	16,1	16,1	16,1
	107,5	13,5	13,8	14,0	14,2	14,4	14,5	14,7	14,8	14,9	15,0	15,1	15,2	15,4	15,5	15,6	15,7	15,7	15,8	15,8	15,9	15,9
	110,0	13,2	13,5	13,8	14,0	14,1	14,3	14,4	14,5	14,7	14,7	14,8	15,0	15,1	15,3	15,4	15,4	15,5	15,6	15,6	15,7	15,7
	112,5	13,0	13,3	13,5	13,7	13,9	14,1	14,2	14,3	14,4	14,5	14,6	14,8	14,9	15,0	15,1	15,2	15,3	15,4	15,4	15,5	15,5
	115,0	12,7	13,0	13,2	13,5	13,6	13,8	13,9	14,1	14,2	14,3	14,4	14,5	14,7	14,8	14,9	15,0	15,1	15,1	15,2	15,2	15,3
	117,5	12,4	12,7	13,0	13,2	13,4	13,6	13,7	13,8	13,9	14,0	14,1	14,3	14,5	14,6	14,7	14,8	14,9	14,9	15,0	15,0	15,1
	120,0	12,1	12,5	12,7	12,9	13,1	13,3	13,5	13,6	13,7	13,8	13,9	14,1	14,2	14,4	14,5	14,6	14,6	14,7	14,8	14,8	14,9
	122,5	11,9	12,2	12,5	12,7	12,9	13,1	13,2	13,3	13,5	13,6	13,7	13,9	14,0	14,1	14,2	14,3	14,4	14,5	14,5	14,6	14,6
	125,0	11,6	11,9	12,2	12,4	12,6	12,8	13,0	13,1	13,2	13,3	13,4	13,6	13,8	13,9	14,0	14,1	14,2	14,3	14,3	14,4	14,4
127,5	11,3	11,7	11,9	12,2	12,4	12,6	12,7	12,9	13,0	13,1	13,2	13,4	13,6	13,7	13,8	13,9	14,0	14,1	14,1	14,2	14,2	
130,0	11,0	11,4	11,7	11,9	12,1	12,3	12,5	12,6	12,7	12,8	12,9	13,2	13,3	13,5	13,6	13,7	13,8	13,8	13,9	14,0	14,0	
132,5	10,8	11,1	11,4	11,7	11,9	12,1	12,2	12,4	12,5	12,6	12,7	12,9	13,1	13,2	13,4	13,5	13,5	13,6	13,7	13,7	13,8	
135,0	10,5	10,9	11,2	11,4	11,6	11,8	12,0	12,1	12,3	12,4	12,5	12,7	12,9	13,0	13,1	13,2	13,3	13,4	13,5	13,5	13,6	
137,5	10,2	10,6	10,9	11,2	11,4	11,6	11,7	11,9	12,0	12,1	12,2	12,5	12,6	12,8	12,9	13,0	13,1	13,2	13,3	13,3	13,4	
140,0	10,0	10,3	10,6	10,9	11,1	11,3	11,5	11,6	11,8	11,9	12,0	12,2	12,4	12,6	12,7	12,8	12,9	13,0	13,0	13,1	13,1	
142,5	9,7	10,1	10,4	10,6	10,9	11,1	11,2	11,4	11,5	11,7	11,8	12,0	12,2	12,3	12,5	12,6	12,7	12,7	12,8	12,9	12,9	
145,0	9,4	9,8	10,1	10,4	10,6	10,8	11,0	11,2	11,3	11,4	11,5	11,8	12,0	12,1	12,2	12,4	12,5	12,5	12,6	12,7	12,7	
147,5	9,1	9,5	9,9	10,1	10,4	10,6	10,8	10,9	11,1	11,2	11,3	11,5	11,7	11,9	12,0	12,1	12,2	12,3	12,4	12,5	12,5	
150,0	8,9	9,3	9,6	9,9	10,1	10,3	10,5	10,7	10,8	11,0	11,1	11,3	11,5	11,7	11,8	11,9	12,0	12,1	12,2	12,2	12,3	

6. **Cleaning**

Clean the enclosure and stand of the ASCENDO System M-S with a dry and soft cloth. Don't use water or other chemicals. Don't touch the tweeter and the woofer.